

REVISIONS			
REV.	DESCRIPTION	DATE	APPROVED
A	INITIAL RELEASE	3/9/2022	BS

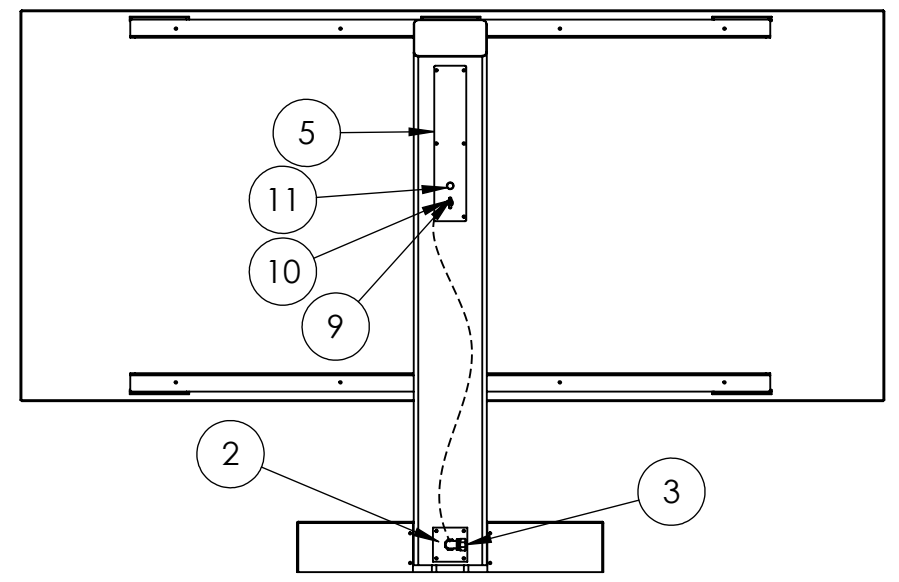
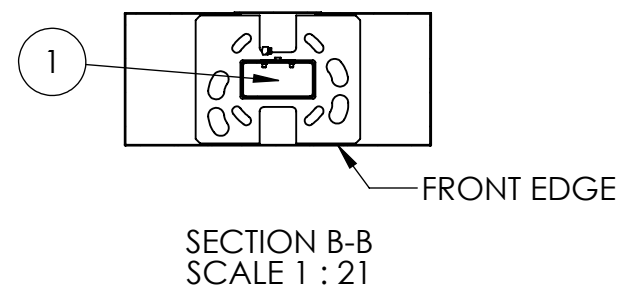
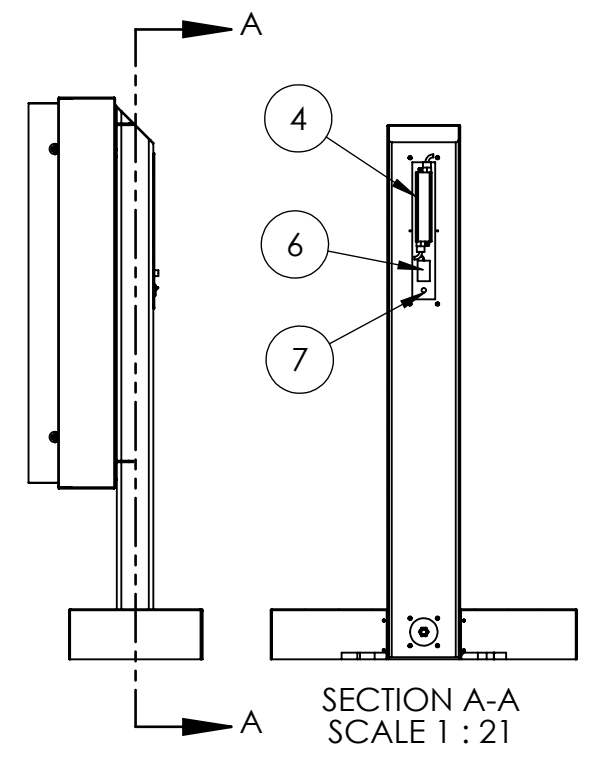
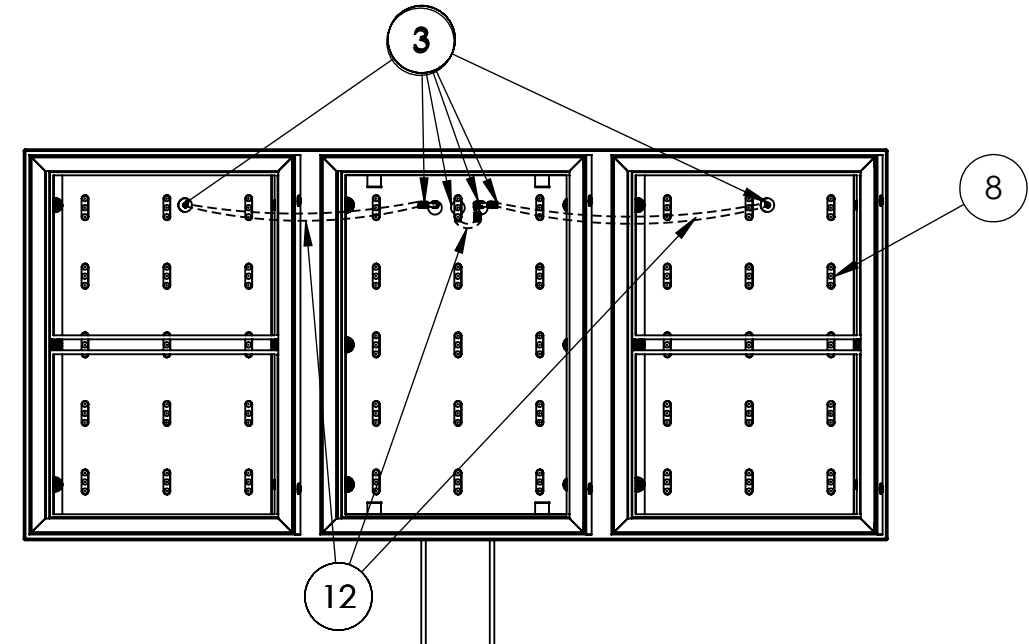
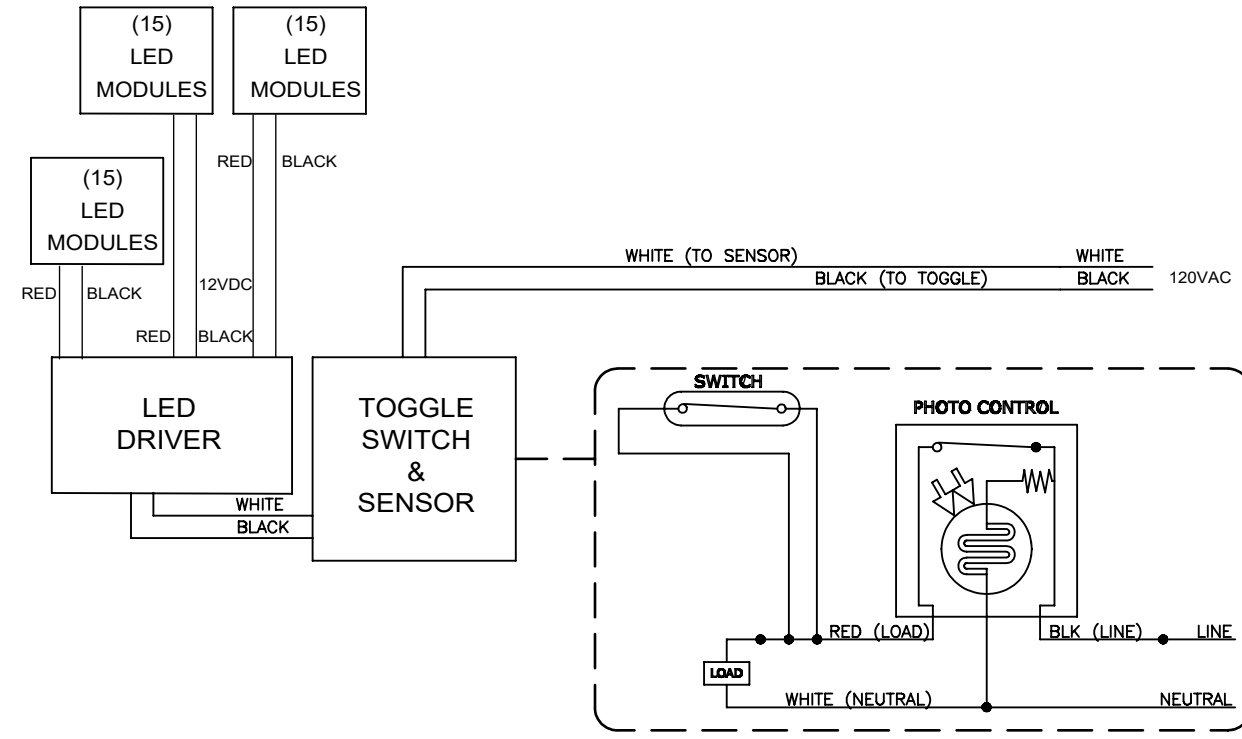

0.518A TYP (0.8A MAX) CURRENT DRAW 120VAC

STARBUCKS DRIVE-THRU ELECTRICAL COMPONENTS

ITEM NO.	PART NO.	DESCRIPTION	QTY
1	NA	STUB UP LOCATION IN STEEL MOUNT PLATE	1
2	233-012-120	LARGE POST WIRING CONNECTOR PLATE	1
3	0081-0101	90 DEGREE 1/2" CONNECTOR 3422-8	6
4	218-000-0034	SLOAN LED DRIVER	1
5	218-002-0010S	POST PANEL COVER WIRED	1
6	228-000-0044	PHOTO SENSOR	1
7	0150-0004	TOGGLE SWITCH	1
8	0024-0050	SLOAN PRISM LED MODULES	45
9	0150-0010	RUBBER BOOT(FOR SWITCH)	1
10	228-000-0054	INDICATOR ON/OFF STICKER	1
11	0035-0014	LIGHT SHIELD	1
12	0018-0079	ANACONDA FLEX CONDUIT	3

TITLE:		SBUX REVO 5 PANEL ELECTRICAL	
DWG. NO.	SBR5ELECSBUX	REV	A
SCALE: 1:21	SHEET SIZE: B	SHEET 1 OF 1	

WEIGHT: 374.41	DRAWN BY: NAME DC	DATE: 5/5/2021
MATERIAL: VARIES	RAW PART #:	
FINISH: PSB6865 BLACKBOARD	RAW QTY:	UOM:
DO NOT SCALE DRAWING		

4

3

2

1

REVISIONS				
ZONE	REV.	DESCRIPTION	DATE	APPROVED
	A	INITIAL RELEASE	5/5/2021	DC
	B	UPDATE BOM	5/20/2021	NB

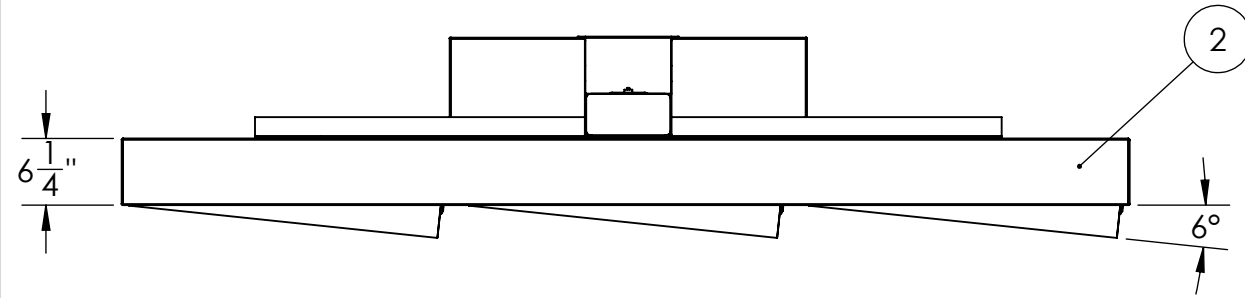

NOTE: ITEMS 6, 7, 8, & 11 NOT VISIBLE

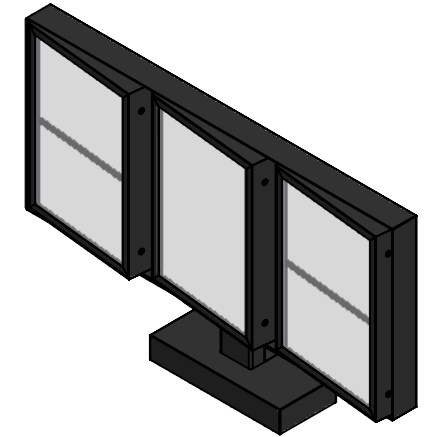

3D VIEW
FOR REFERENCE ONLY

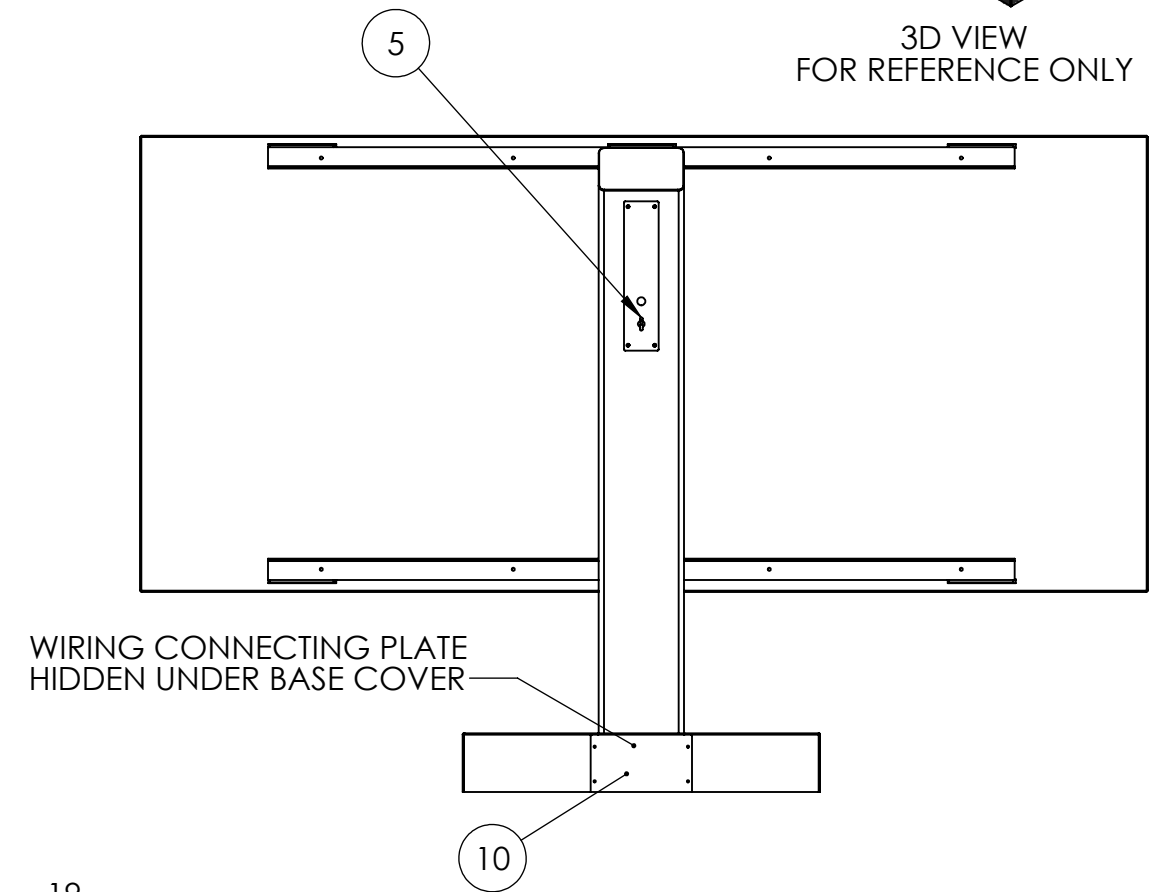
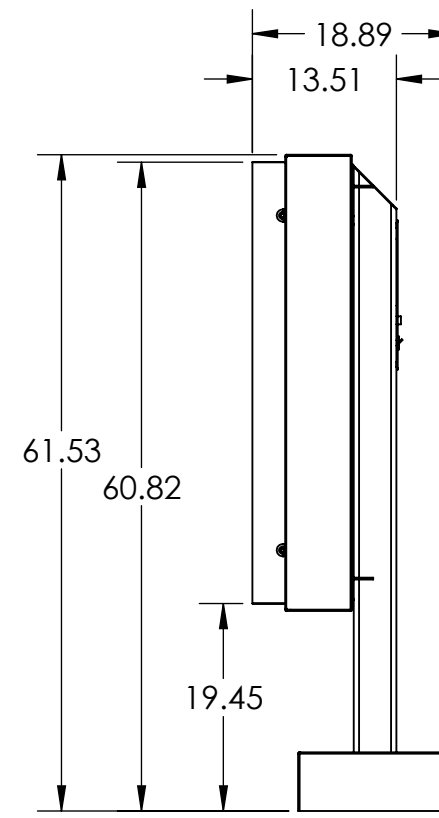
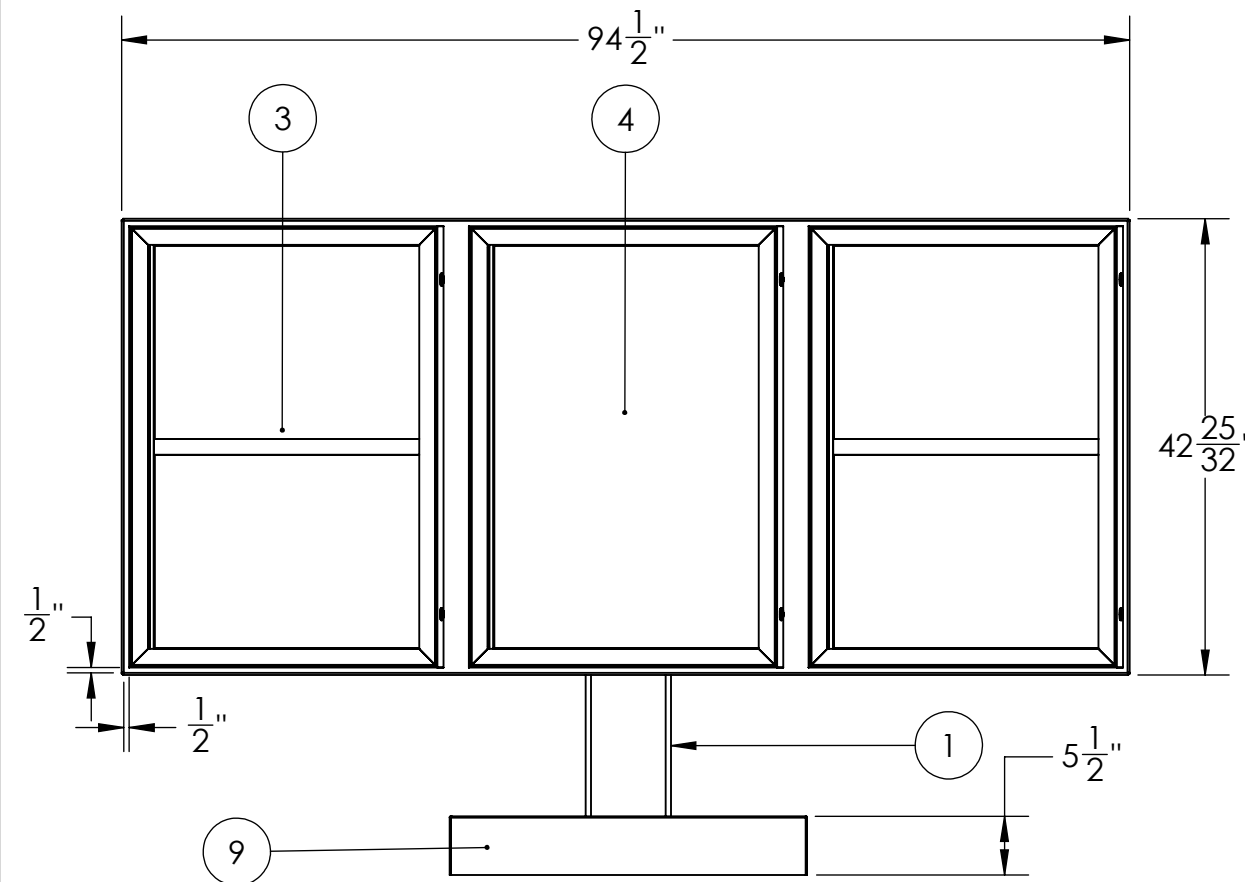

WIRING CONNECTING PLATE
HIDDEN UNDER BASE COVER

ITEM NO.	PART #	DESCRIPTION	FINISH	QTY.
1	233-022-0001S	SBUX REVO 5P WELDED POST POWDERED	PSB6865 BLACKBOARD	1
2	233-022-0060	5P SHROUD POWDERED	PSB6865 BLACKBOARD	1
3	SBRMENUM	SB MENU BOARD E-FRAME	PSB6865 BLACKBOARD	2
4	SBRMENUMC	SB MENU BOARD C-FRAME	PSB6865 BLACKBOARD	1
5	218-002-0010S	POST PANEL COVER WIRED	PSB6865 BLACKBOARD	1
6	0055-0050	Fitting for Flexible Plastic Conduit, Long 90 Degree Elbow, 1/4 Trade Size Female x M12 Male	BLACK	6
7	0018-0101	90 DEGREE 1/2" CONNECTOR 3422-8	RAW	1
8	0120-0026	THREADED INSERT 1/4-20, # ATEAEK-420-260	ZINC-PLATED	8
9	233-012-0070	3/5 BASE COVER FRONT POWDERED	PSB6865 BLACKBOARD	1
10	233-012-0080	3/5 BASE COVER REAR POWDERED	PSB6865 BLACKBOARD	1
11	233-012-0120	LARGE POST WIRING CONNECTION PLATE POWDERED	PSB6865 BLACKBOARD	1

TITLE:

SBUX REVO 5P
PROTOV1

DWG. NO.

SBR5PROTOV1

REV

B

WEIGHT:
359.91
MATERIAL:
VARIES
FINISH:
PSB6865 BLACKBOARD
DO NOT SCALE DRAWING

DRAWN BY:

NAME
DC

DATE
5/5/2021

RAW PART #:

RAW QTY:

UOM:

SCALE: 1:18 SHEET SIZE: B SHEET 1 OF 1

4

3

2

1